

Repair Parts for Use with Electric or Pneumatic VT Series Terminal Unit Valves 1/2 in., Two-Way and Three-Way

Description

The available packing kits and spring kits can extend the service life of the VT Series valves. No inner valve kits are available for this series of valves.

Selection Charts

Ring Pack Packing Kits for VT Series Valves

Code Number	Callout	Description
V-9999-608	A	Single pack
V-9999-610		10 pack (contains enough material to repack 10 valves)
V-9999-630		50 pack (contains U-cups and O-rings only to repack 50 valves)
V-9999-649	B	Packing nut for all VT styles

Spring Kits for VT Series Valves

Code Number	Callout	Spring Range, psig	Actuator	Valve Size, in.	Valve Body
V-9999-6001 ¹	C	3 to 6	V-3802 or V-4000	1/2	VT Series
V-9999-6002 ¹		4 to 8			
V-9999-6003 ¹		9 to 13			
V-3752-6023 ²	D	3 to 6	V-3000	1/2	VT Series
V-4332-6001 ²		4 to 8			
V-3752-6022 ²		9 to 13			

1. Spring kit includes spring, upper spring seat, upper spring seat retainer, and instructions.
2. Spring kit includes spring, upper and lower spring seat, stem extension, stem lock screw, and instructions.

Tailpiece and Nut for VT Series Valves

Code Number	Description	Tube Size, in.	Valve Size, in.	Valve Body
V-9999-663	Tailpiece	3/8	1/2	VT Series
V-9999-664	Tailpiece	1/2	1/2	
V-9999-665	Tailpiece	3/4	1/2	
V-9999-666	Nut	3/8 and 1/2	1/2	
V-9999-667	Nut	3/4	1/2	

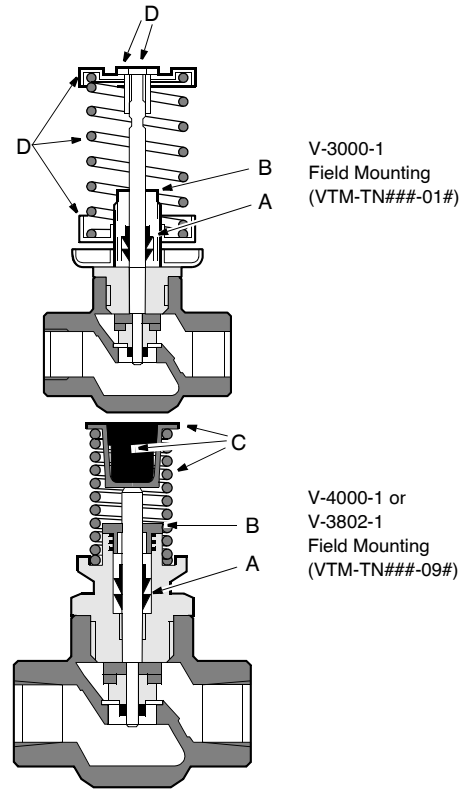

V-3000-1
Field Mounting
(VTM-TN###-01#)

V-4000-1 or
V-3802-1
Field Mounting
(VTM-TN###-09#)

Repair Parts, VT Series Valves