

OSID Smoke Detection

Open-area Smoke Imaging Detection (OSID) by Xtralis is a new innovation in projected beam smoke detection technology. By using advanced dual wavelength projected beams and optical imaging technology, OSID provides a low-cost, reliable and easy-to-install solution that overcomes typical beam detection issues such as false alarm incidents and alignment difficulties.



Unique Detection Technology

The OSID system measures the level of smoke entering beams of light projected over an area of protection. A single OSID Imager can detect up to seven Emitters to provide a wide coverage area. Two innovations in smoke detection technology have been developed for the revolutionary OSID smoke detector:

Dual Wavelength Particle Detection

The beam projected from each Emitter contains a unique sequence of ultraviolet (UV) and infrared (IR) pulses that are synchronized with the Imager and enable the rejection of any unwanted light sources.

By using two wavelengths of light to detect particles, the system is able to distinguish between particle sizes. The shorter UV wavelength interacts strongly with both small and large particles while the longer IR wavelength is affected only by larger particles. Dual wavelength path loss measurements therefore enable the detector to provide repeatable smoke obscuration measurements, while rejecting the presence of dust particles or solid intruding objects.

Optical Imaging with a CMOS Imaging Chip

An optical imaging array in the OSID Imager provides the detector with a wide viewing angle to locate and track multiple Emitters. Consequently, the system can tolerate a much less precise installation and can compensate for the drift caused by natural shifts in building structures.

Optical filtering, high-speed image acquisition and intelligent software algorithms also enable the OSID system to provide new levels of stability and sensitivity with greater immunity to high level lighting variability.

Operation

Status information (Fire Alarm, Trouble and Power) is communicated through the Imager via Status LEDs, dedicated Trouble and Alarm relays, and the Remote Indicator interface. Specific Trouble (Fault) conditions are identified through coded flashes of the Trouble LED.

An internal heating option is also provided on the Imager to prevent condensation on the optical surface, and a reset input enables an external signal to reset the device.

Simple Installation and Maintenance

The OSID system consists of up to seven Emitters, for the 45° and 90° Imager units, located along the perimeter of the protected area, and an Imager mounted opposite. Each component can be mounted directly to the surface or can be secured with the supplied mounting brackets. Battery powered Emitters with up to five years battery life are also available to reduce installation time and cost.

Features

- Maximum detection range of 492 ft. (150 meters) for the OSI-10
- Status LEDs for Fire, Trouble and Power
- High false alarm immunity
- Dust and intrusive solid object rejection
- Easy alignment with large adjustment and viewing angles
- No need for precise alignment
- Tolerant of alignment drift
- Automatic commissioning in under ten minutes
- Simple DIP switch configuration
- Dual wavelength LED-based smoke detection
- Simple and easy maintenance requirements
- Conventional alarm interface for straightforward fire system integration
- Three selectable alarm thresholds

Listings/Approvals

- UL
- ULC
- AFNOR
- CE - EMC and CPD
- VdS
- ActivFire
- Major Agency Approvals pending

OSID Smoke Detection

On the Imager, a termination card provides all field wiring terminals, and DIP switches enable the user to configure the detector for particular applications.

Alignment of the Emitter is simply achieved using a laser alignment tool to rotate the optical spheres until the laser beam projected from the alignment tool is close to the Imager.

The Imager is aligned in a similar way so that its Field of View (FOV) encompasses all Emitters. A Trouble or Fault will be indicated if an Emitter is missing or outside the Imager field of view.

The OSID system is highly tolerant to dust and dirt and requires little maintenance in practice. Preventative maintenance is limited to occasionally cleaning the optical faces of the detector components.

Configuration Options

OSID systems may be configured to suit a range of detection spaces by selecting the number of Emitters and type of Imager. Each type of Imager differs by the lens used in the unit, which determines the field of view and range of the system.

Imager	Field of View		Detection Range				Max. Number of Emitters
	Horizontal	Vertical	Standard Power		High Power		
			Min	Max	Min	Max	
10°	7°	4°	98 ft. (30 m)	492 ft. (150 m)	--	--	1
45°	38°	19°	49 ft. (15 m)	197 ft. (60 m)	98 ft. (30 m)	393 ft. (120 m)	7
90°	80°	48°	20 ft. (6 m)	** 111 ft. (34 m)	39 ft. (12 m)	** 223 ft. (68 m)	7

** Maximum Distances measured for the Center Field of View of the Imager. For more details on distances for the Imager, see the OSID Product Guide.

Emitter / Imager Dimensions

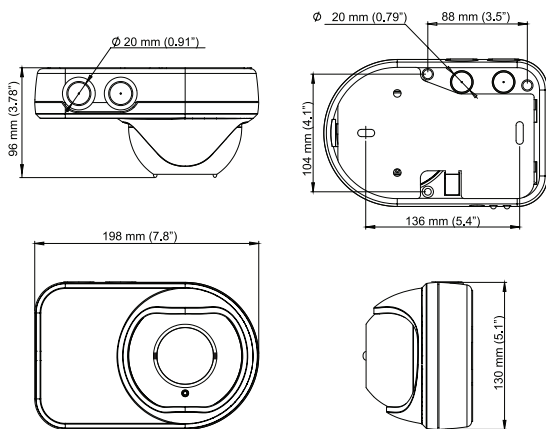

Ordering Codes

OSI-10	Imager - 7° coverage	OSID-INST	OSID Installation Kit
OSI-45	Imager - 38° coverage	OSP-001	FTDI Cable 1.5m
OSI-90	Imager - 80° coverage	OSP-002	Laser Alignment Tool
OSE-SP	Emitter - Standard Power		
OSE-SPW	Emitter - Standard Power, Wired		
OSE-HPW	Emitter - High Power, Wired		

Specifications

Supply Voltage

20 to 30 VDC (24 VDC nominal)

Imager Current Consumption

Nominal (at 24 VDC):

8 mA (1 Emitter)

10 mA (7 Emitters)

Peak (at 24 VDC) during training mode: 31 mA

Emitter Current Consumption

Wired Version (at 24 VDC):

350 µA Std Power, 800 µA High Power

Battery Version:

Built-in 5 Year Battery

Field Wiring

Cable Gauge

0.2 - 4 mm² (26-12 AWG)

Alarm Threshold Levels:

Low - Highest sensitivity / earliest alarm: 20% (0.97 dB)

Medium - Medium sensitivity: 35% (1.87 dB)

High - Lowest sensitivity / maximum immunity to nuisance smoke conditions: 50% (3.01 dB)

Adjustment Angle

±60° (horizontal)

±15° (vertical)

Maximum Misalignment Angle

± 2°

Dimensions (WHD)

Emitter / Imager:

7.80 in. x 5.12 in. x 3.78 in.

(198 mm x 130 mm x 96 mm)

Operating Conditions*

Temperature:

14 °F to 131 °F (-10 °C to 55 °C)*

Humidity:

10 to 95% RH (non-condensing)

Please consult your Xtralis office for operation outside these parameters.

IP Rating

IP 44 for Electronics

IP 66 for Optics Enclosure

Status LEDs

Fire Alarm (Red)

Trouble / Power (Bi-color Yellow / Green)

Approvals Compliance

Please refer to the Product Guide for details regarding compliant design, installation and commissioning.

* Product UL listed for use from 32°F to 104°F (0°C to 38°C)

www.xtralis.com

The Americas +1 781 740 2223 Asia +852 2916 8876 Australia and New Zealand +61 3 9936 7000

UK and Europe +44 1442 242 330 Middle East +962 6 569 1083

The contents of this document are provided on an "as is" basis. No representation or warranty (either express or implied) is made as to the completeness, accuracy or reliability of the contents of this document. The manufacturer reserves the right to change designs or specifications without obligation and without further notice. Except as otherwise provided, all warranties, express or implied, including without limitation any implied warranties of merchantability and fitness for a particular purpose are expressly excluded.

This document includes registered and unregistered trademarks. All trademarks displayed are the trademarks of their respective owners. Your use of this document does not constitute or create a licence or any other right to use the name and/or trademark and/or label.

This document is subject to copyright owned by Xtralis AG ("Xtralis"). You agree not to copy, communicate to the public, adapt, distribute, transfer, sell, modify or publish any contents of this document without the express prior written consent of Xtralis.

Doc. no. 19797_18

Part No. LF29582

OSID
by  **xtralis™**