

TR100 WALL MODULE

The Honeywell TR100 Wall Module is an advanced, highly configurable device that provides building automation connectivity that is well-suited for commercial building applications. TR100 can replace existing Honeywell wall modules using the existing tools familiar to installers. The Honeywell TR100 wall modules utilize Sylk™ communication, which is polarity insensitive and uses two wires. This device also supports BACnet™ MS/TP and Modbus™ RTU communications via RS-485 bus, which is prevalent in HVAC building control systems.

Additionally, these protocols Modbus™ RTU, BACnet™ MS/TP, and Sylk™ enable future firmware updates and enhance functionality. The Honeywell TR100 Wall Module works with Honeywell and third-party controllers and is not based on proprietary protocols. The Wall Module features an attractive capacitive touchscreen interface and allows easy configuration, requiring minimal installation training. The module also features embedded help screens that make setup intuitive, reducing reliance on technical manuals for complex system setups.



Honeywell TR100 Wall Module with capacitive touch screen

FEATURES AND HIGHLIGHTS

EASY-TO-USE DESIGN

- Color, capacitive touchscreen display for intuitive, fast commissioning and exceptional user experience.
- Multiple display modes like Auto dim display mode and always on dim mode.
- An LED ring indicator to show the operational status.

MULTI-SENSOR

- Home screen can display one to three of any of the following parameters:
 - Temperature Setpoint
 - Room Temperature
 - Room Humidity
 - CO₂ (TR42 emulation and BACnet™ MS/TP, Modbus™ RTU)
 - Outdoor Humidity
 - Outdoor Temperature
 - One of any virtually parameter in the controller.

BUILT FOR FLEXIBILITY

- Restricted tenant access to controller parameters or imposed HVAC settings limits via password protection.
- Permanent retention of user configuration, including setpoints after a power outage.
- Ability to assign labels for enumerated values.
- Access and adjust most parameters in the Honeywell controller.
- Access and adjust the controller schedule.
- Balance the VAV system from the wall module.

PART NUMBERS DESCRIPTION

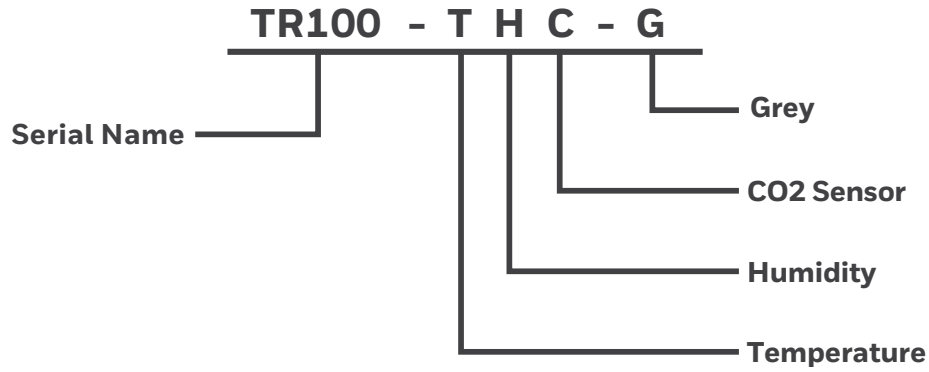

PART NUMBERS

TR100 WALL MODULE PART NUMBERS			
PART NUMBER	SENSORS	COMMUNICATION PROTOCOL	POWER
TR100-TH-G	Temperature, Humidity	Modbus™ RTU, BACnet™ MS/TP, Sylk™	24 VAC/VDC or Sylk™
TR100-THC-G	Temperature, Humidity and CO2	Modbus™ RTU, BACnet™ MS/TP, Sylk™	24 VAC/VDC or Sylk™

ACCESSORIES/REPLACEMENT PARTS*	
PART NUMBER	DESCRIPTION
TRTC-DECOPLATE-1	TR100 deco plate.

*NOTE: These accessories are available by separate order.

DIMENSION

TR100 WALL MODULE DIMENSIONS

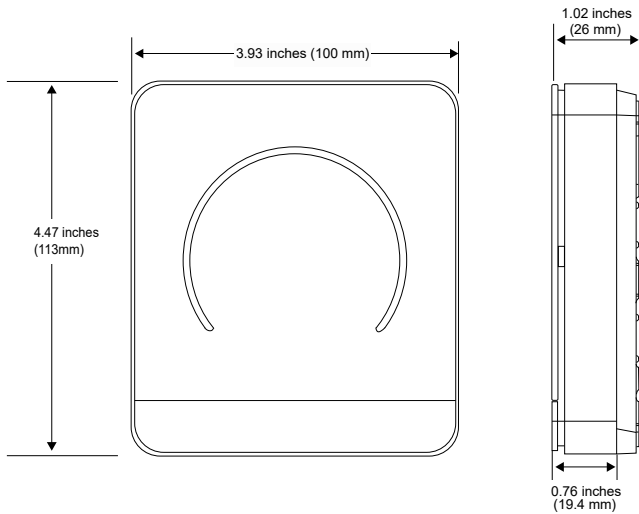

TRTC-DECOPLATE-1 DIMENSIONS

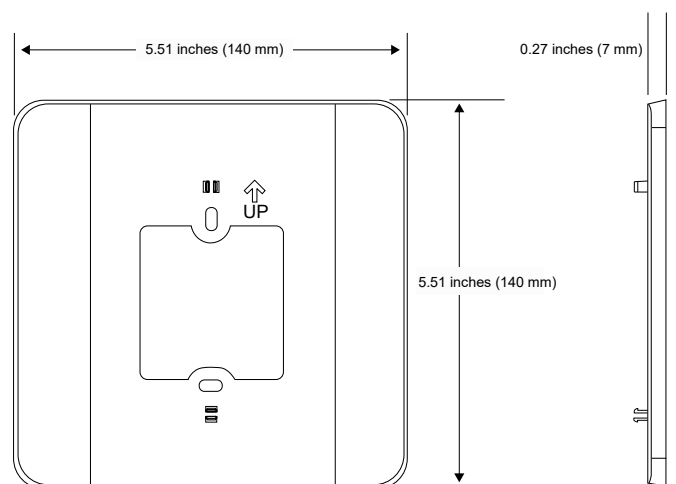

All dimensions are in inches (mm).

WEIGHT AND DIMENSIONS	
PARAMETER	SPECIFICATION
Dimension (L x W x H)	3.93 x 1.02 x 4.47 inches (100 x 26 x 113 mm)
Weight	0.52 lbs. (238 grams)

TECHNICAL SPECIFICATION

POWER CHARACTERISTICS	
PARAMETER	SPECIFICATION
Power Supply	Rated Voltage: 24 VAC 50/60 Hz Working Voltage Range: (1) 24 VAC 50/60 Hz, 20 to 30 VAC (2) 24 VDC, 20 to 30 VDC or (3) Power over Sylk™ communication
Power Consumption (Display ON)	Max. 3.2 VA @ 24 VAC (0.8 W - 0.9 W @ 24 VDC/ Sylk™)
Supported Devices on Sylk™	Sylk™ Powered: 1. Emulate TR42/TR42-H, supports up to (2) devices. 2. Emulate TR42-CO2/TR42-H-CO2 and TR7x/TR7x-H, supports maximum (1) device. 3. Connect external 24 VAC/VDC power supply, if multi-devices work.

DISPLAY	
PARAMETER	SPECIFICATION
Display Type	16 BPP TFT display with CTP
Resolutions	320 x 240 pixel
Active Display Area	2.4" diagonally
Backlight	LCD (Dimmable)
LED Color Ring	Blue (Cooling)
	Orange (Heating)

ONBOARD SENSOR		
PARAMETER	SPECIFICATION	DETAILS
Temperature	Resolution:	1 °F (0.5 °C)
	Accuracy:	±1 °F (0.5 °C) at room temperature
Humidity	Range:	20 to 90 % RH
	Resolution:	1 % RH
	Control Accuracy:	±3 % RH at room temperature
CO2	Measure Range:	400 to 5000 ppm
	Sensor output resolution:	1 ppm
	Accuracy:	± (50 ppm ± 2.5 % reading) @ 400-1000 ppm
± (50 ppm ± 3 % reading) @ 1001-2000 ppm		
± (40 ppm ± 5 % reading) @ 2001-5000 ppm		

ELECTRICAL CHARACTERISTICS	
PARAMETER	SPECIFICATION
Rated Impulse Voltage	500 V
Construction of Control	Independently Mounted Control
Operation Method	Type 1 Action
Pollution Degree	2
Purpose of Control	Operating Control

WIRE SPECIFICATION	
PARAMETER	SPECIFICATION
Wire Gauge	14 to 26 AWG (0.2 to 1.5 mm ² for solid or stranded, max 2.5 mm ² for solid wires)
Wire Type	Copper

OPERATING ENVIRONMENT	
PARAMETER	SPECIFICATION
Ambient Operating Temperature	32 to 122 °F (0 to 50 °C)
Ambient Operating Humidity	10 to 90 % relative humidity (non-condensing)
Storage Temperature	-40 to 150 °F (-40 to 65.5 °C)
Protection Class	IP20

COMMUNICATION	
PARAMETER	SPECIFICATION
Sylk™	Honeywell Sylk™
BACnet™ MS/TP	(9.6, 19.2, 38.4, 57.6, 76.8, 115.2 Kbps)
Modbus™ RTU	0.3 to 115.2 Kbps

CONTROLLER COMPATIBILITY
The TR100 is open protocol and can connect to the below mentioned controllers using BACnet™ MS/TP, Modbus™ RTU and Sylk™. BACnet™ MS/TP and Modbus™ RTU: All Honeywell and 3 rd party Controllers will support standard BACnet™ MS/TP, Modbus™ RTU communications.
Sylk™: Optimizer Supervisor:
<ul style="list-style-type: none"> Spyder classic Stryker CIPer Model 30 Optimizer Unitary
Comfort Point™ Open (CPO):
<ul style="list-style-type: none"> CPO-Rxx CPO-VAV2A Optimizer Unitary Optimizer VAV

COMPLIANCE	
PARAMETER	SPECIFICATION
Certificate	<ul style="list-style-type: none"> CE FCC ICES Prop65 REACH RoHs UK UL/cUL
Standards	<ul style="list-style-type: none"> BS EN 60730-1 BS EN 60730-2-9 EN60730-1 EN60730-2-9 ICES-003 Title 47part 15 subpart B UL60730-1 UL60730-2-9

TECHNICAL SPECIFICATION

REPLACEABILITY

A TR42-H, TR42-CO2, TR42-H-CO2, TR75, TR75-H, TR71-H, TR71-TH, TR120-H, TR120-TH with wall modules wired to the controller in the field can be directly replaced by the TR100-TH-G or TR100-THC-G; simply remove the old wall module and install the new wall module (including new backplate). The backplate sizes and mounting holes are identical. The TR100 will accept the TR42 or TR75 file configuration (proxy file) downloaded from the existing controller and provide the same configuration and functionality in a nicer touch screen user interface. TR100 Wall Modules can directly accept a TR42 or TR75 application download from the controller without any modifications in the controller and in the engineering tool.

TERMINAL IDENTIFICATION

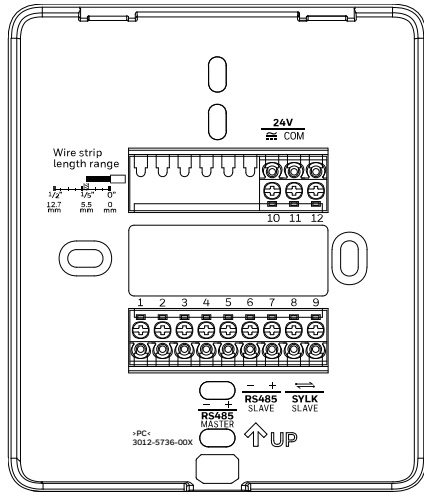

TERMINAL DESCRIPTION

TERMINAL NUMBER	TERMINAL LABEL	TERMINAL NAME	LABEL DESCRIPTION
4	-	RS485 MASTER	Reserved for future use
5	+		
6	-	RS485 SLAVE	BACnet™ MS/TP / Modbus™ RTU Communications
7	+		
8	↔	Sylk™ SLAVE	Sylk™, Slave , power input
9			
10	≡	24 V POWER	24 VAC power from Class-2 transformer, 24 VDC positive pole
11	COM	COM	24 VAC common (Neutral) from Class-2 transformer, 24 VDC common

TR100 FEATURE COMPARISON

FEATURE	TR75 EMULATION				TR42 EMULATION			TR100 (BACnet™ MS/TP / Modbus™ RTU)	
	TR100-TH-G	TR120	TR75	TR71	TR100-TH-G	TR100-THC-G	TR42	TR100-TH-G	TR100-THC-G
Color Touch	✓	✓	-	-	✓	✓	-	✓	✓
Usability/Display	Swipe & Touch	Touch	Predefined Buttons	Predefined Buttons	Swipe & Touch	Swipe & Touch	Predefined Buttons	✓	✓
Sensing: Temperature, Humidity	✓	✓	✓	✓	✓	✓	✓	✓	✓
Sensing: CO2	-	-	-	-	-	✓	✓	-	✓
Temperature Setpoint	✓	✓	✓	✓	✓	✓	✓	✓	✓
Override	✓	✓	✓	✓	✓	✓	✓	✓	✓
Fan	✓	✓	✓	✓	✓	✓	✓	✓	✓
Customizable Parameters	✓	✓	✓	✓ (limited)	-	-	-	✓	✓
VAV Balancing	✓	✓	✓	✓ (limited)	-	-	-	-	-
Schedule Access	✓	✓	✓	-	-	-	-	-	-
User Management levels	2	2	2	2	2	2	2	4	4
Communication Protocol	Sylk™	Sylk™	Sylk™	Sylk™	Sylk™	Sylk™	Sylk™	BACnet™ MS/TP / Modbus™ RTU	BACnet™ MS/TP / Modbus™ RTU
Alarms	-	-	-	-	-	-	-	✓	✓
Firmware Updates	✓	-	-	-	✓	✓	-	with HON Tools	with HON Tools

GENERAL SAFETY INFORMATION

- When performing any work (installation, mounting, startup), all manufacturer instructions and in particular the Mounting and Installation Instructions Guide - 31-00673 and the User Guide - 31-00674 are to be observed.
- TR100 Wall Module may be installed and mounted only by authorized and trained personnel.
- Rules regarding electrostatic discharge should be followed.
- If TR100 Wall Module is modified in any way, except by the manufacturer, all warranties concerning operation and safety are invalidated.
- Make sure that the local standards and regulations are observed at all times.
- Use only accessory equipment which comes from or has been approved by Honeywell.
- It is recommended that out-of-the-box devices be kept at room temperature for at least 24 hours before applying power. This is to allow any condensation resulting from low shipping/storage temperatures to evaporate.
- Investigated according to United States Standard UL-60730-1, and UL60730-2-9.
- Investigated according to Canadian National Standard(s) C22.2, No. 205-M1983 (CNL-listed).
- Do not open TR100 Wall Module, as it contains no user serviceable parts inside!
- CE declarations according to EMC Directive 2014/30/EU.
- UK declarations according to Electromagnetic Compatibility Regulations 2016.
- Product standards are EN 60730-1 and EN 60730-2-9.
- TR100 Wall Module is Class B digital apparatus and complies with Canadian ICES-003.
- This device complies with part 15 of the FCC Rules. Operation is subject to the following two conditions: (1) This device may not cause harmful interference, and (2) this device must accept any interference received, including interference that may cause undesired operation.
- Caution: Changes or modifications to this unit not expressly approved by the party responsible for compliance could void the user's authority to operate the equipment.
- Prudence: Les changements ou modifications apportés à cet appareil non expressément approuvés par la partie responsable de la conformité pourraient annuler le droit de l'utilisateur à utiliser l'équipement.
- This equipment has been tested and found to comply with the limits for a Class B digital device, pursuant to part 15 of the FCC Rules. These limits are designed to provide reasonable protection against harmful interference in a residential installation. This equipment generates uses and can radiate radio frequency energy and, if not installed and used in accordance with the instructions, may cause harmful interference to radio communications. However, there is no guarantee that interference will not occur in a particular installation. If this equipment does cause harmful interference to radio or television reception, which can be determined by turning the equipment off and on, the user is encouraged to try to correct the interference by one or more of the following measures:
 - Reorient or relocate the receiving antenna.
 - Increase the separation between the equipment and receiver.
 - Connect the equipment into an outlet on a circuit different from that to which the receiver is connected.
 - Consult the dealer or an experienced radio/TV technician for help.
- Limited by local law regulations, version for North America does not have region selection option.

SAFETY INFORMATION AS PER EN60730-1

TR100 Wall Module is intended for residential and commercial environments.

TR100 Wall Module is an independently mounted electronic control system with fixed wiring.

TR100 Wall Module is used for the purpose of building HVAC control and is suitable for use only in non-safety controls for installation on or in appliances.

Note:

All images used in this document are for illustrative purposes only and may not match the actual product.

By using this Honeywell literature, you agree that Honeywell will have no liability for any damages arising out of your use or modification to, the literature. You will defend and indemnify Honeywell, its affiliates and subsidiaries, from and against any liability, cost, or damages, including attorneys' fees, arising out of, or resulting from, any modification to the literature by you.

Honeywell | Building Automation

715 Peachtree Street, N.E.,

Atlanta, Georgia, 30308,

United States

buildings.honeywell.com

@U.S. Registered Trademark
© 2024 Honeywell International Inc.
31-00671-01 | Rev 05-24

