

G250S-N Technical Data Sheet



Technical Data

Fluid	chilled or hot water, up to 60% glycol, steam
Flow characteristic	modified equal percentage
Controllable flow range	stem up - open A – AB
Valve Size [mm]	2" [50]
Pipe connection	NPT female ends
Housing	Bronze
Stem	316 stainless steel
Stem seal	EPDM O-ring
Seat	Stainless steel AISI 316
Valve plug	316 stainless steel
Body Pressure Rating	ANSI Class 250, up to 400 psi below 150°F
ANSI Class	250
Maximum Inlet Pressure (Steam)	100 psi [690 kPa]
Max Differential Pressure (Steam)	50 psi [345 kPa]
Maximum differential pressure (water)	50 psi (345 kPa)
Rangeability Sv	100:1
Cv	40
Weight	7.7 lb [3.5 kg]
Fluid Temp Range (water)	20...338°F [-7...170°C]
Leakage rate	ANSI Class VI
Servicing	repack kits available

Flow/Mounting Details

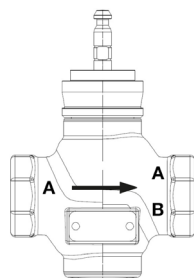

Application

This valve is typically used in air handling units on heating or cooling coils, and fan coil unit heating or cooling coils. Some other common applications include unit ventilators, VAV box re-heat coils and bypass loops. This valve is suitable for use in hydronic systems with variable flow. Bronze and stainless steel trim valves can be used for steam applications, depending on actuator and close-off combinations.

Suitable Actuators

	Non-Spring	Spring	Electronic fail-safe
G250S-N	LVB(X)	NF	LVKB(X)

Dimensions (Inches [mm])

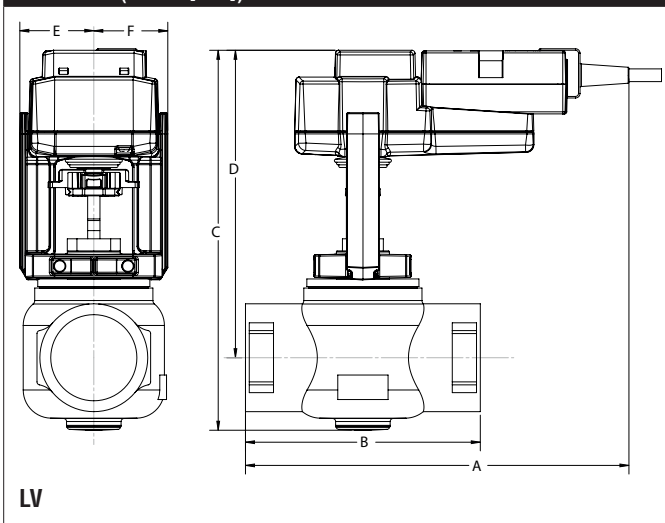

A	B	C	D	E	F
10.0" [254]	6.1" [156]	9.9" [252]	8.0" [203]	1.9" [48]	

Safety Notes

WARNING: This product can expose you to lead which is known to the State of California to cause cancer and reproductive harm. For more information go to www.p65warnings.ca.gov

Piping

The valves should be mounted in a weather-protected area in a location that is within the ambient limits of the actuator. Allow sufficient room for valve with actuator and for service. The G2 and G3 preferred mounting position of the valve is with the valve stem vertical above the valve body, for maximum life. However, the assemblies can be mounted with the valve stem vertical or horizontal in relation to the pipe. The actuators should never be mounted underneath the valve, as condensation can build up and result in a failure of the actuators.

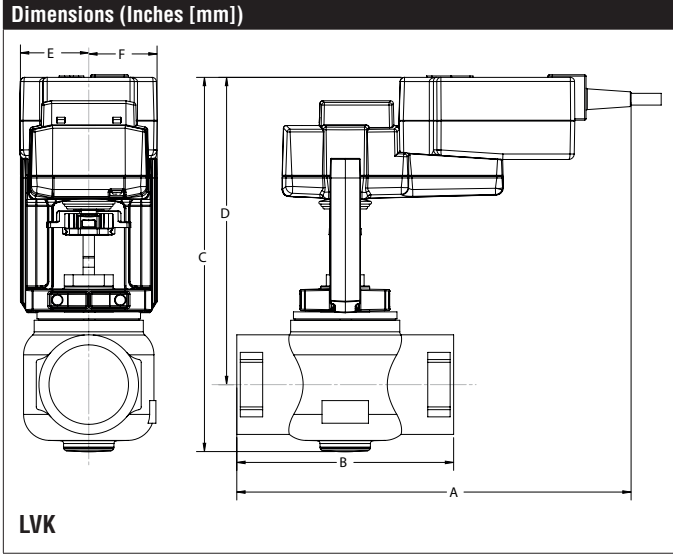

A	B	C	D	E	F
11.0" [280]	6.1" [156]	10.5" [267]	8.8" [224]	1.9" [48]	

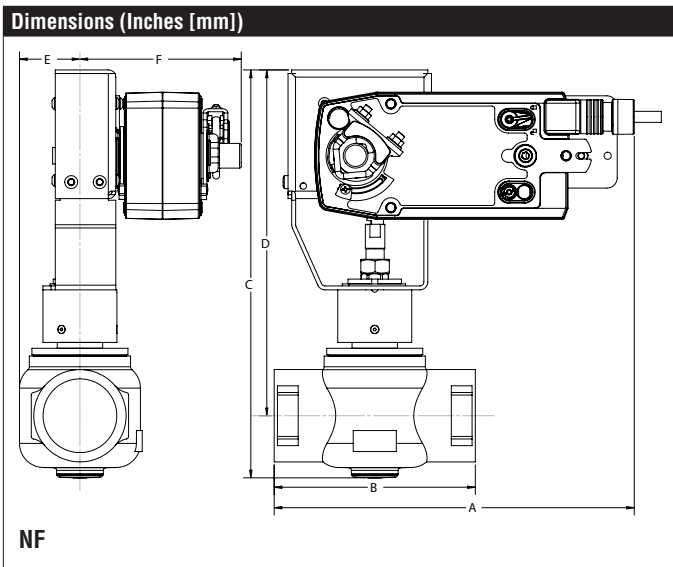

A	B	C	D	E	F
10.9" [277]	6.1" [156]	12.4" [314]	10.5" [267]	1.8" [46]	4.9" [125]