

EFB24-MFT - Damper Actuator

Modulating, Spring Return, 24 V, Multi-Function Technology®



Technical Data	
Power Supply	24 VAC, ±20%, 50/60 Hz, 24 VDC, -10% / +20%
Power Consumption Running	9.5 W
Power Consumption Holding	4.5 W
Transformer Sizing	16 VA (class 2 power source)
Shaft Diameter	1/2" to 1.05" round, centers on 3/4" with insert, 1.05" without insert
Electrical Connection	3ft [1m], 18 GA appliance cable with 1/2" conduit connector
Overload Protection	electronic throughout 0° to 95° rotation
Electrical Protection	actuators are double insulated
Operating Range Y	2 to 10 VDC, 4 to 20 mA w/ ZG-R01 (500 Ω, 1/4 W resistor), variable (VDC, PWM, floating point, on/off)
Input Impedance	100 k Ω for 2 to 10 VDC (0.1 mA), 500 Ω for 4 to 20 mA, 1500 Ω for PWM, floating point and On/Off
Feedback Output U	2 to 10 VDC, 0.5 mA max, VDC variable
Angle of Rotation	Max. 95°, adjustable with mechanical end stop, 35° to 95°
Nominal Torque	Min. 270 in-lbs [30 Nm]
Direction of Rotation (Motor)	reversible with built-in switch
Direction of Rotation (Fail-Safe)	reversible with CW/CCW mounting
Position Indication	visual indicator, 0° to 95° (0° is full spring return position)
Manual Override	5 mm hex crank (3/16" Allen), supplied
Running Time (Motor)	default 150 sec, variable 60...150 sec
Running Time (Fail-Safe)	<20 sec @ -4°F to 122°F [-20°C to 50°C], <60 sec @ -22°F [-30°C]
Angle of Rotation Adaptation	off (default)
Override Control	min. position = 0% , mid. Position = 50% , max. position = 100% (Default)
Ambient Humidity	max. 95% RH non-condensing
Ambient Temperature Range	-22°F to 122°F [-30°C to 50°C]
Storage Temperature Range	-40°F to 176°F [-40°C to 80°C]
Housing	NEMA 2, IP54, UL Enclosure Type 2
Housing Material	Aluminum die cast and plastic casing
Agency Listings†	cULus acc. to UL60730-1A/-2-14, CAN/CSA E60730-1:02, CE acc. to 2004/108/EC
Noise Level (Motor)	≤45.3 dB (A) @ 150 sec, run time dependent
Noise Level (Fail-Safe)	≤71 dB (A)
Servicing	maintenance free
Quality Standard	ISO 9001
Weight	9.8 lb [4.4 kg]
Degree of Protection IEC/EN	IP54

*Variable when configured with MFT options.

†Rated Impulse Voltage 800V, Type of action 1.AA, Control Pollution Degree 3

Torque min. 270 in-lb, for control of air dampers, Control 2 to 10 VDC (Default), Feedback 2 to 10 VDC (Default)

Application

For fail-safe, modulating control of dampers in HVAC systems. Actuator sizing should be done in accordance with the damper manufacturer's specifications. A feedback signal is provided for position indication or master-slave applications. Two EF's can be piggybacked for torque loads of up to 540 in-lbs. Minimum 3/4" diameter shaft. OR Maximum of three EF's can be piggybacked for torque loads of up to 810 in-lbs. Minimum 1" diameter shaft. Master-Slave wiring for either configuration.

Default/Configuration

Default parameters for 2 to 10 VDC applications of the EF.-MFT actuator are assigned during manufacturing. If required, custom versions of the actuator can be ordered. The parameters are variable and can be changed by three means: Factory pre-set or custom configuration, set by the customer using PC-Tool software or the handheld ZTH US.

Operation

The EF..24-MFT actuator provides 95° of rotation and is provided with a graduated position indicator showing 0° to 95°. The actuator will synchronize the 0° mechanical stop or the physical damper mechanical stop and use this point for its zero position during normal control operations. A unique manual override allows the setting of any actuator position within its 95° of rotation with no power applied. This mechanism can be released physically by the use of a crank supplied with the actuator. When power is applied the manual override is released and the actuator drives toward the fail-safe position. The actuator uses a brushless DC motor which is controlled by an Application Specific Integrated Circuit (ASIC) and a microprocessor. The microprocessor provides the intelligence to the ASIC to provide a constant rotation rate and to know the actuator's exact position. The ASIC monitors and controls the brushless DC motor's rotation and provides a Digital Rotation Sensing (DRS) function to prevent damage to the actuator in a stall condition. The position feedback signal is generated without the need for mechanical feedback potentiometers using DRS. The actuator may be stalled anywhere in its normal rotation without the need of mechanical end switches. The EF..24-MFT is mounted directly to control shafts up to 1.05" diameter by means of its universal clamp and anti-rotation bracket. A crank arm and several mounting brackets are available for damper applications where the actuator cannot be direct coupled to the damper shaft. The spring return system provides minimum specified torque to the application during a power interruption. The EF..24-MFT actuator is shipped at 5° (5° from full fail-safe) to provide automatic compression against damper gaskets for tight shut-off.

Installation Note: Use flexible metal conduit. Push the UL listed conduit fitting device over the actuator's cable to butt against the enclosure. Screw in conduit connector. Jacket the actuator's input wiring with UL listed flexible conduit. Properly terminate the conduit in a suitable junction box.

EFB24-MFT - Damper Actuator

Modulating, Spring Return, 24 V, Multi-Function Technology®

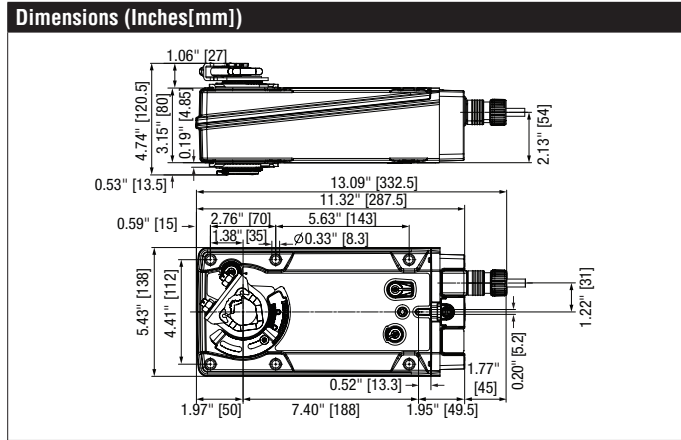

EFB24-MFT - Damper Actuator

Modulating, Spring Return, 24 V, Multi-Function Technology®



Accessories	
AV8-25	9.8" shaft extension for 5/16" to 1" diameter shafts.
EF-P	Anti-rotation bracket EFB(X)/GKB(X)/GMB(X).
IND-EFB	EFB(X) position indicator.
K9-2	Standard EFB(X) clamp (1/2" to 1.05").
KG10A	Ball joint for 3/8" diameter rod, zinc plated.
KH10	Univ. crankarm, slot 21/64" w, for 9/16" to 1" dia. shafts.
KH-EFB	EFB(X) crankarm (with 1.05" diameter shaft pass through).
SH10	Push rod for KG10A ball joint (36" L, 3/8" diameter).
TOOL-07	13 mm wrench.
ZG-100	Univ. right angle bracket (17" H x 11-1/8" W x 6" base).
ZG-120	Jackshaft mounting bracket.
ZG-DC1	Damper clip for damper blade, 3.5" width.
ZG-DC2	Damper clip for damper blade, 6" width.
ZG-EFB	EFB(X) crankarm adaptor kit.
ZG-JSA-3	1.05" diameter jackshaft adaptor (12" L).
ADS-100	Analog to digital switch for modulating actuators.
IRM-100	Input rescaling module for modulating actuators.
MFT-P	Belimo MFT configuration software (hardware not included).
PS-100	Actuator power supply and control simulator.
PTA-250	Pulse width modulation interface for modulating actuators.
SGA24	Positioner control for modulating actuators (surface mount).
SGF24	Positioner control for modulating actuators (flush mount).
TF-CC US	Cable conduit connector, 1/2".
UK24BAC	BACnet gateway module for up to 8 MFT actuators.
UK24LON	LON gateway module for up to 8 MFT actuators.
UK24MOD	MODbus gateway module for up to 8 MFT actuators.
ZG-R01	4 to 20 mA adaptor, 500Ω, 1/4 W resistor w 6" pigtail wires.
ZG-R02	50% voltage divider kit (resistors with wires).
ZG-SGF	Mounting plate for SGF.
ZG-X40	120 to 24 VAC, 40 VA transformer.
ZK1-GEN	Cable for ZTH US to diagnostic/programming socket.
ZK2-GEN	Cable for ZTH US to actuators w/o diagnostics socket.
ZTH US	Handheld programming tool w/ ZK1-GEN, ZK2-GEN, ZK6-GEN.

Typical Specification

Spring return control damper actuators shall be direct coupled type which require no crank arm and linkage and be capable of direct mounting to a jackshaft up to a 1.05" diameter. The actuator must provide modulating damper control in response to a 2 to 10 VDC or, with the addition of a 500Ω resistor, a 4 to 20 mA control input from an electronic controller or positioner. The actuators must be designed so that they may be used for either clockwise or counter clockwise fail-safe operation. Actuators shall use a brushless DC motor controlled by a microprocessor and be protected from overload at all angles of rotation. Run time shall be constant, and independent of torque. A 2 to 10 VDC feedback signal shall be provided for position feedback or master slave applications. Actuators with auxiliary switches must be constructed to meet the requirements for Double Insulation so an electrical ground is not required to meet agency listings. Actuators shall be cULus listed and have a 5 year warranty, and be manufactured under ISO 9001 International Quality Control Standards. Actuators shall be as manufactured by Belimo.

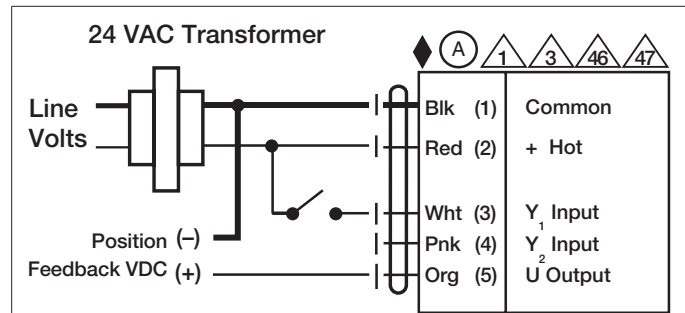

On/Off

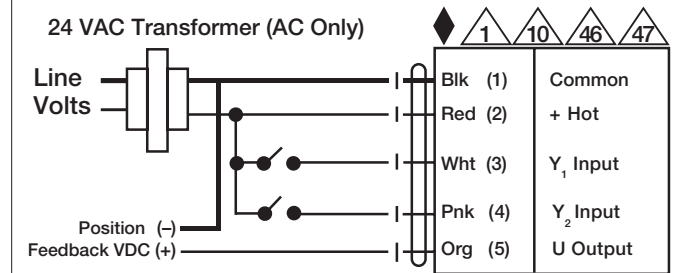

Floating Point

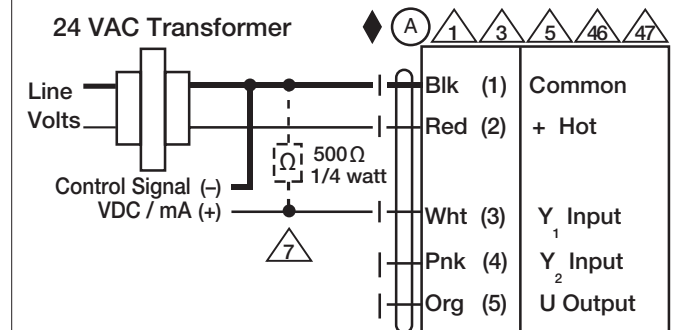

VDC/mA Control

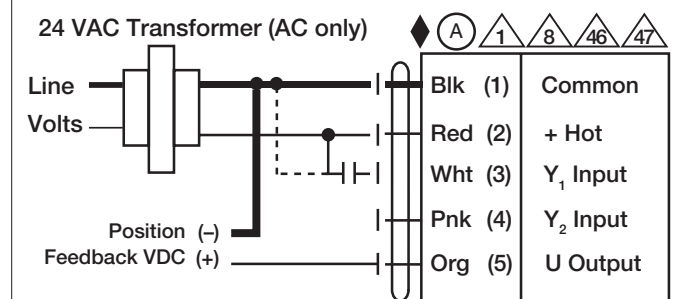

PWM Control

Date created, 02/12/2018 - Subject to change. © Belimo Aircontrols (USA), Inc.

Wiring Diagrams

⚠ WARNING! LIVE ELECTRICAL COMPONENTS!
 During installation, testing, servicing and troubleshooting of this product, it may be necessary to work with live electrical components. Have a qualified licensed electrician or other individual who has been properly trained in handling live electrical components perform these tasks. Failure to follow all electrical safety precautions when exposed to live electrical components could result in death or serious injury.

◆ Meets cULus requirements without the need of an electrical ground connection.

Ⓐ Actuators with appliance cables are numbered.

1 Provide overload protection and disconnect as required.

3 Actuators may also be powered by 24 VDC.

5 Only connect common to negative (-) leg of control circuits.

7 A 500 Ω resistor (ZG-R01) converts the 4 to 20 mA control signal to 10 VDC.

8 Control signal may be pulsed from either the Hot (Source) or Common (Sink) 24 VAC line.

10 For triac sink the Common connection from the actuator must be connected to the Hot connection of the controller. Position feedback cannot be used with a triac sink controller; the actuator internal common reference is not compatible.

12 IN4004 or IN4007 diode. (IN4007 supplied, Belimo part number 40155).

46 Actuators may be controlled in parallel. Current draw and input impedance must be observed.

47 Master-Slave wiring required for piggy-back applications. Feedback from Master to control input(s) of Slave(s).

